

8-2. PCB Diagrams

8-2-1. Top

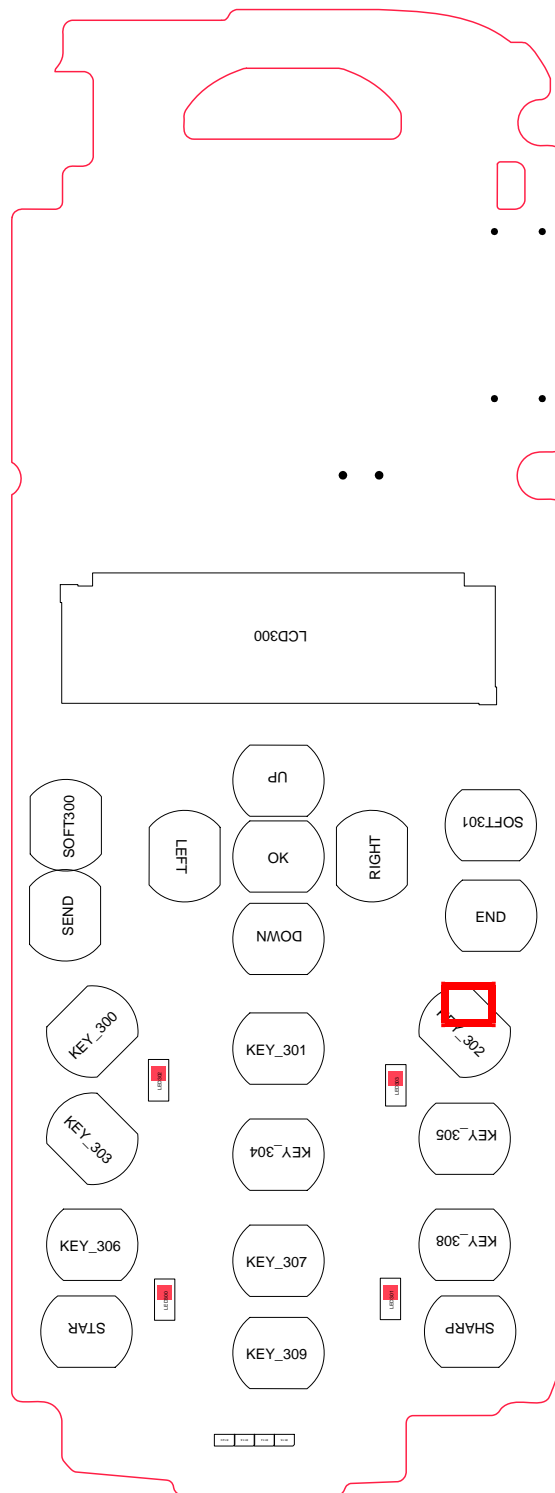

8-2-1. Bottom

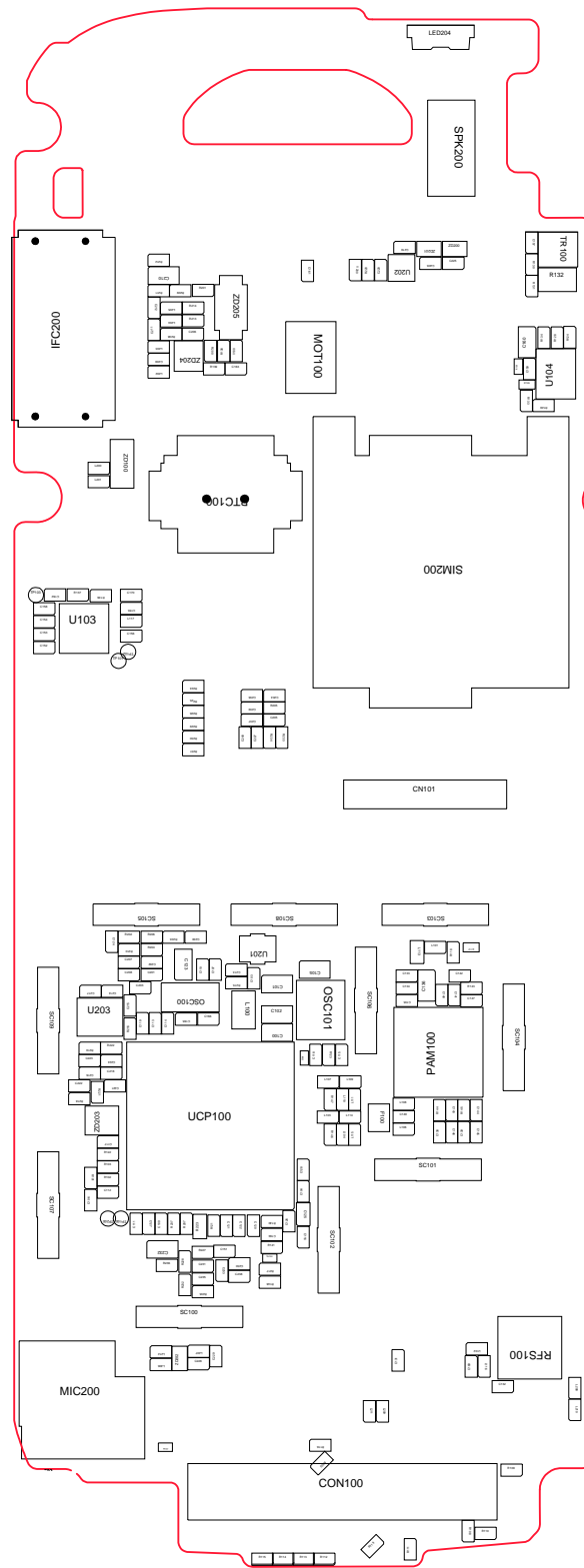

8-3. Flow Chart of Troubleshooting

※ presetting methods for checking TP

- GND & TP(exp. VBUS_5.0V= C159) using Oscilloscope
- look over the coming out signal.

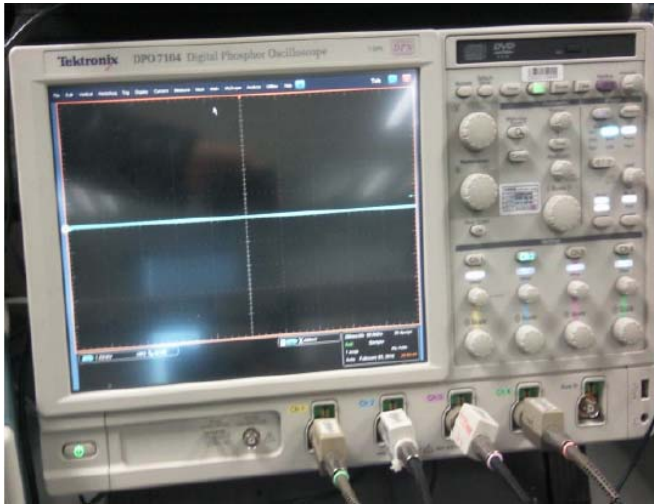

← Oscilloscope



8-3-1. Power On

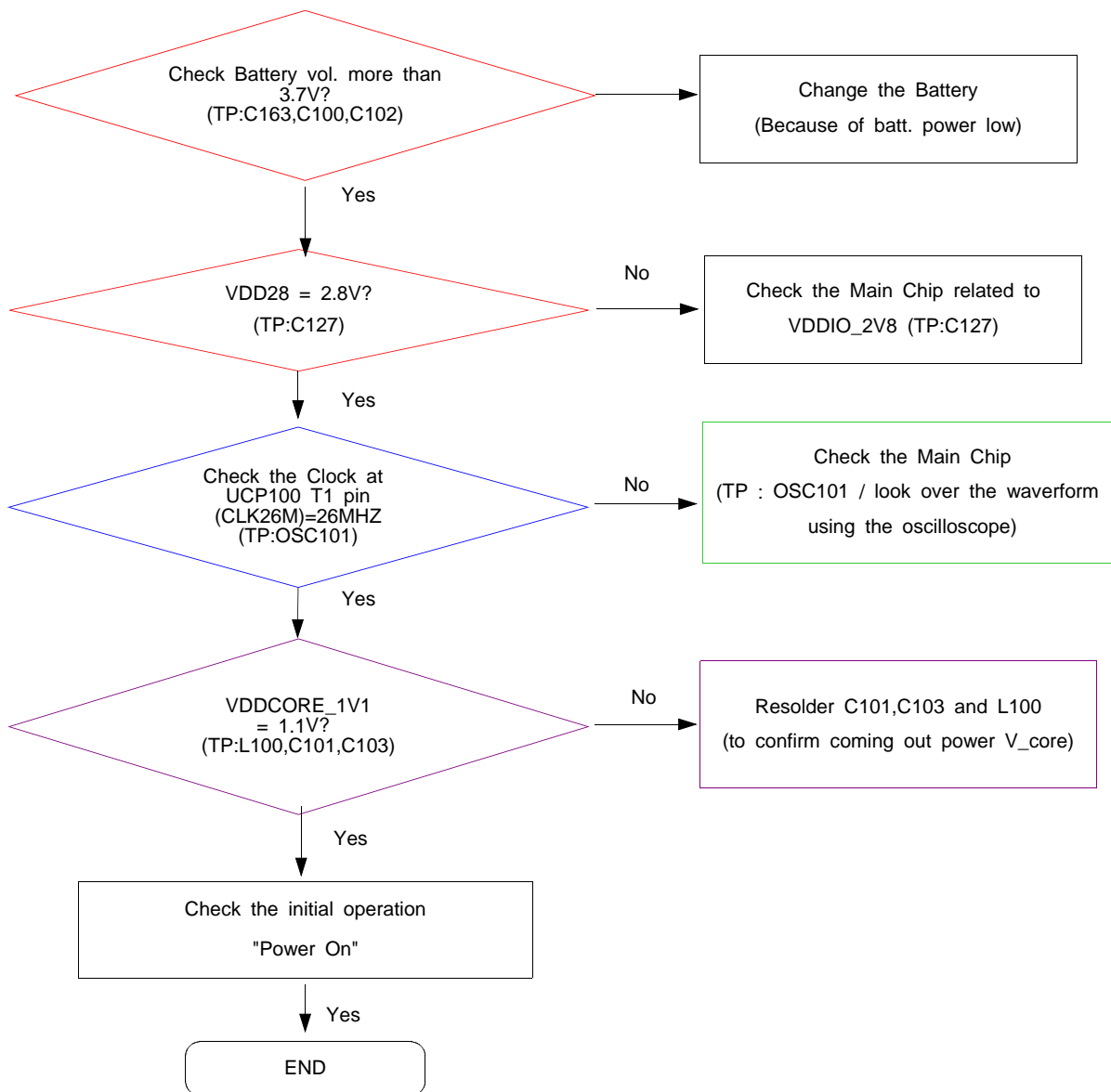

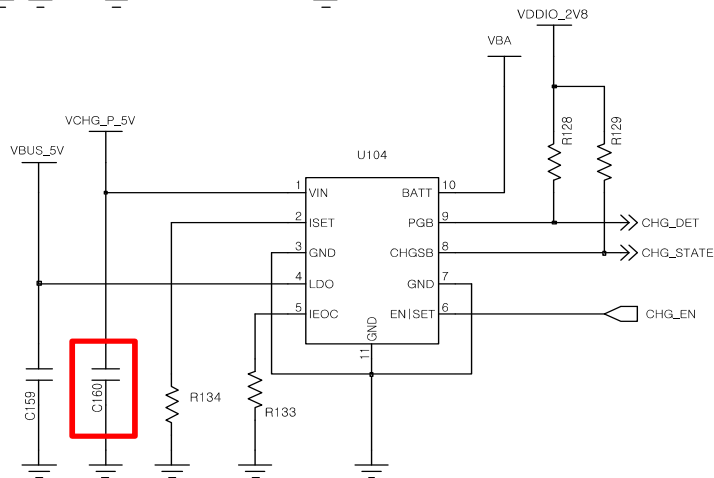
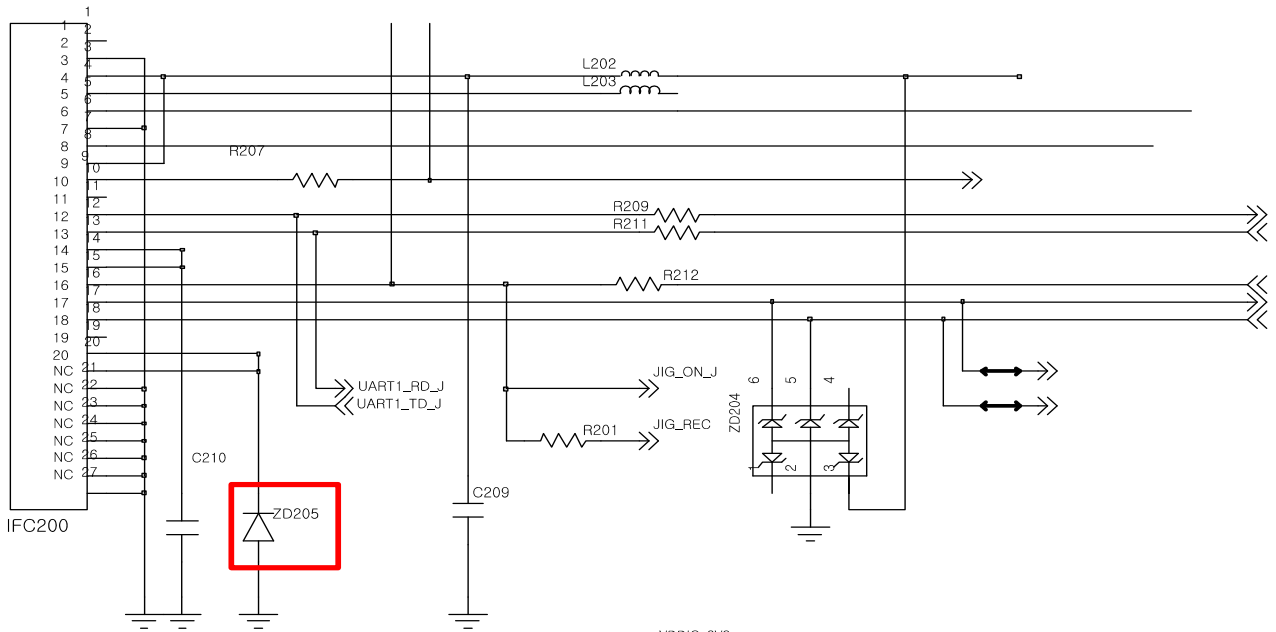
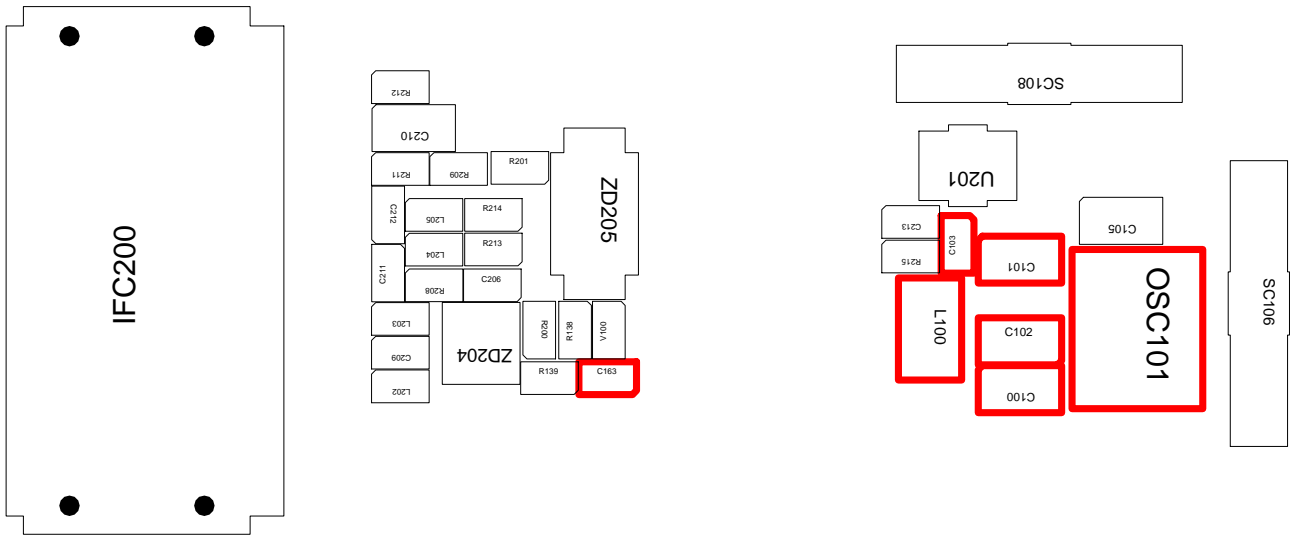

8-3-2. Charging Part

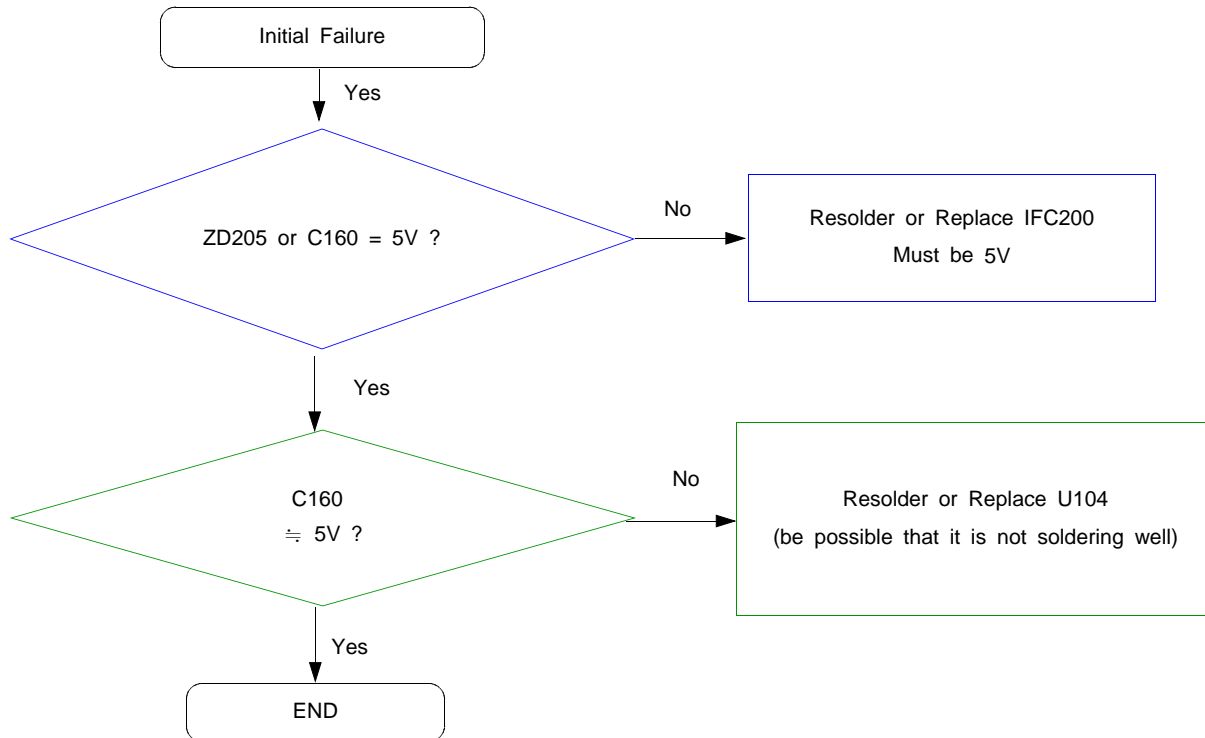

8-3-3. Sim Part

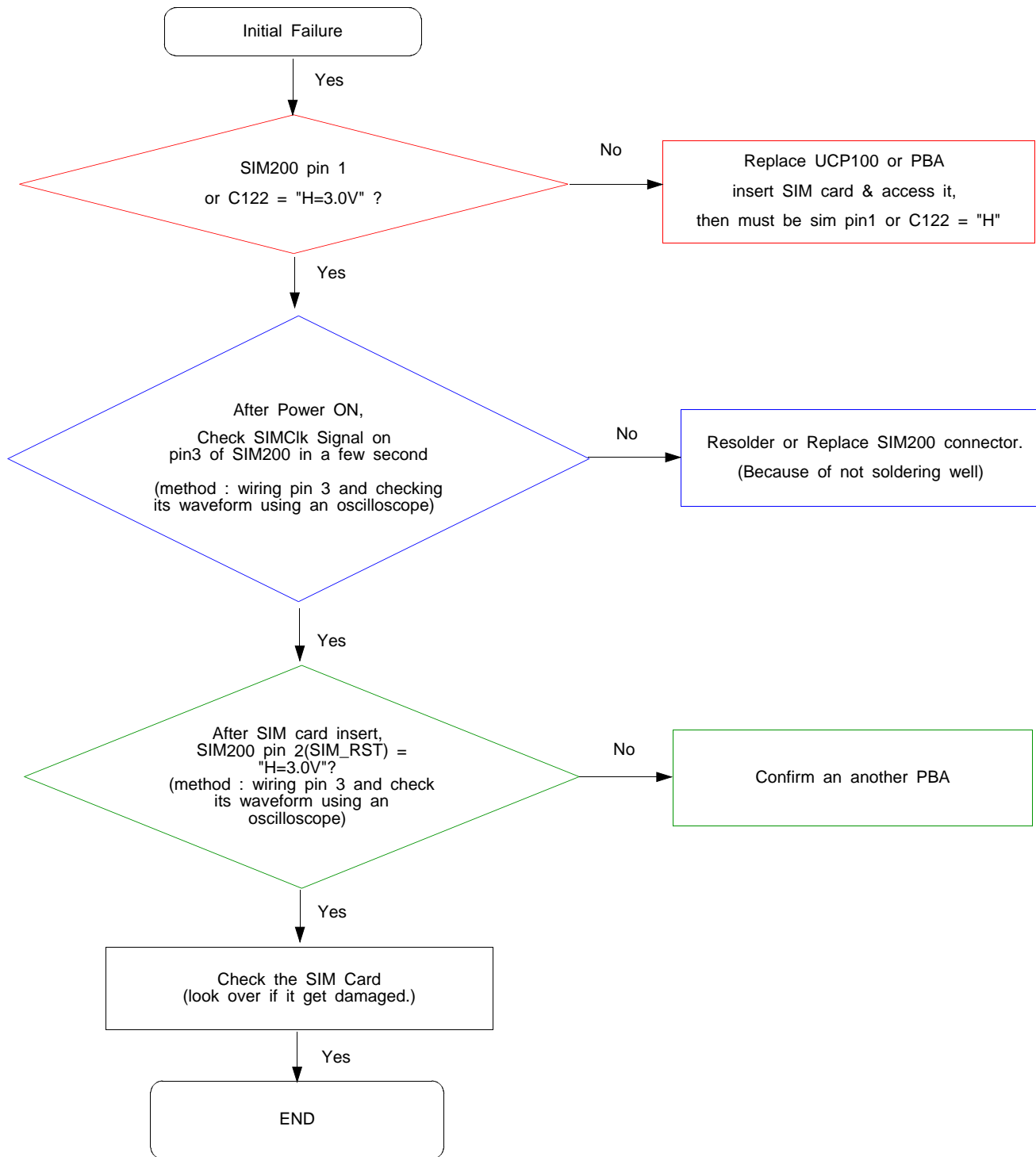

8-3-4. Microphone Part

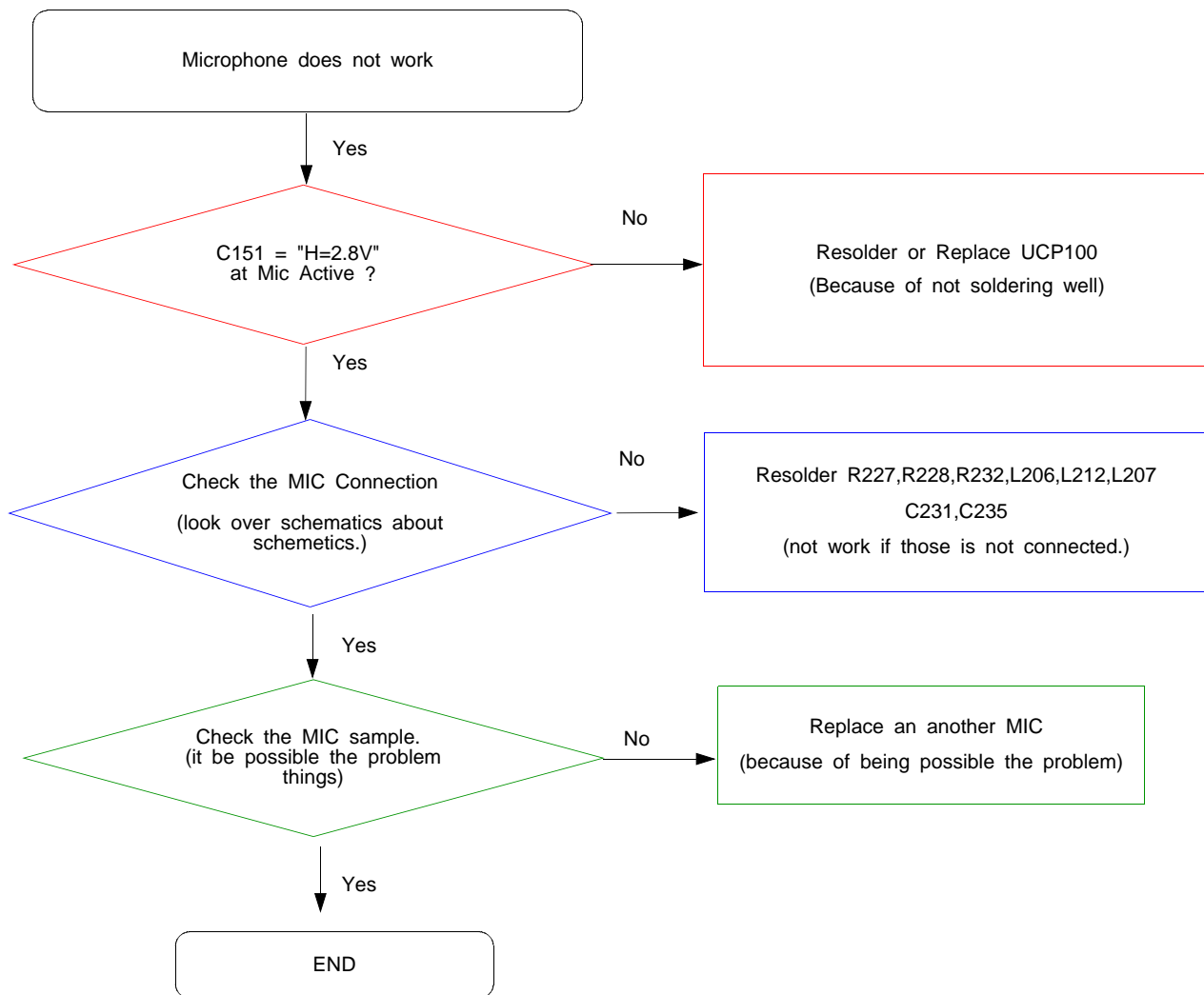

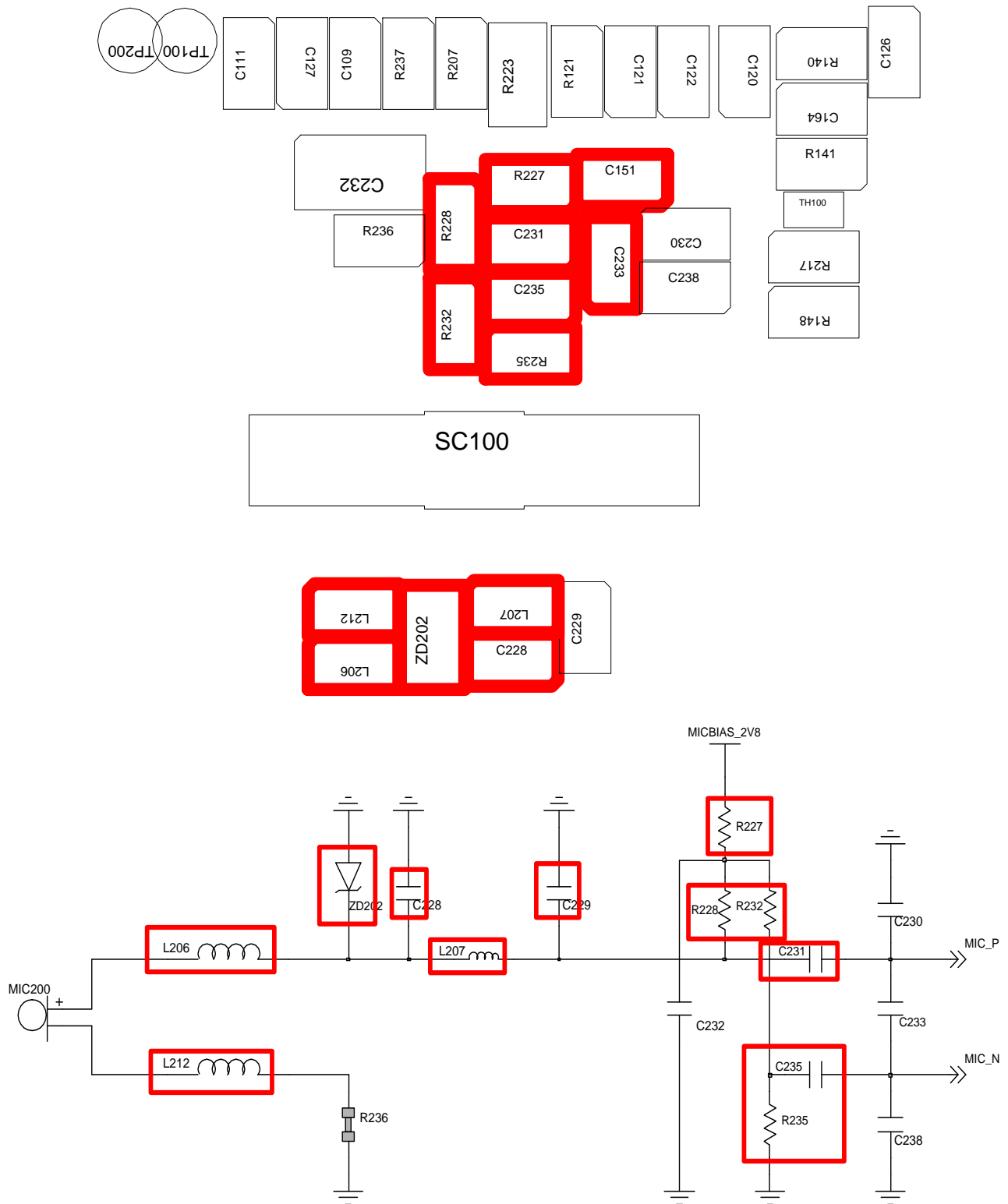

8-3-5. Speaker Part

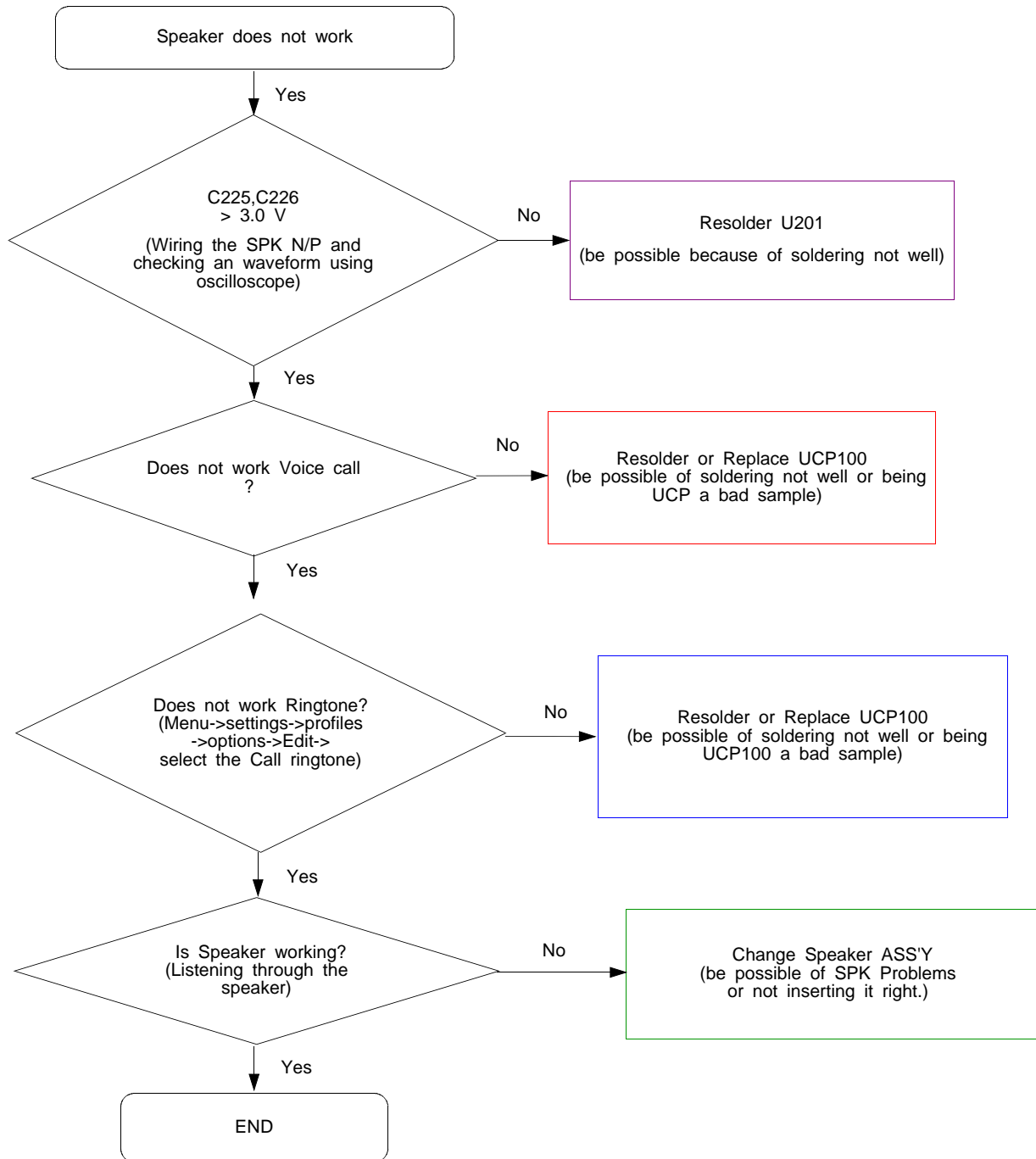

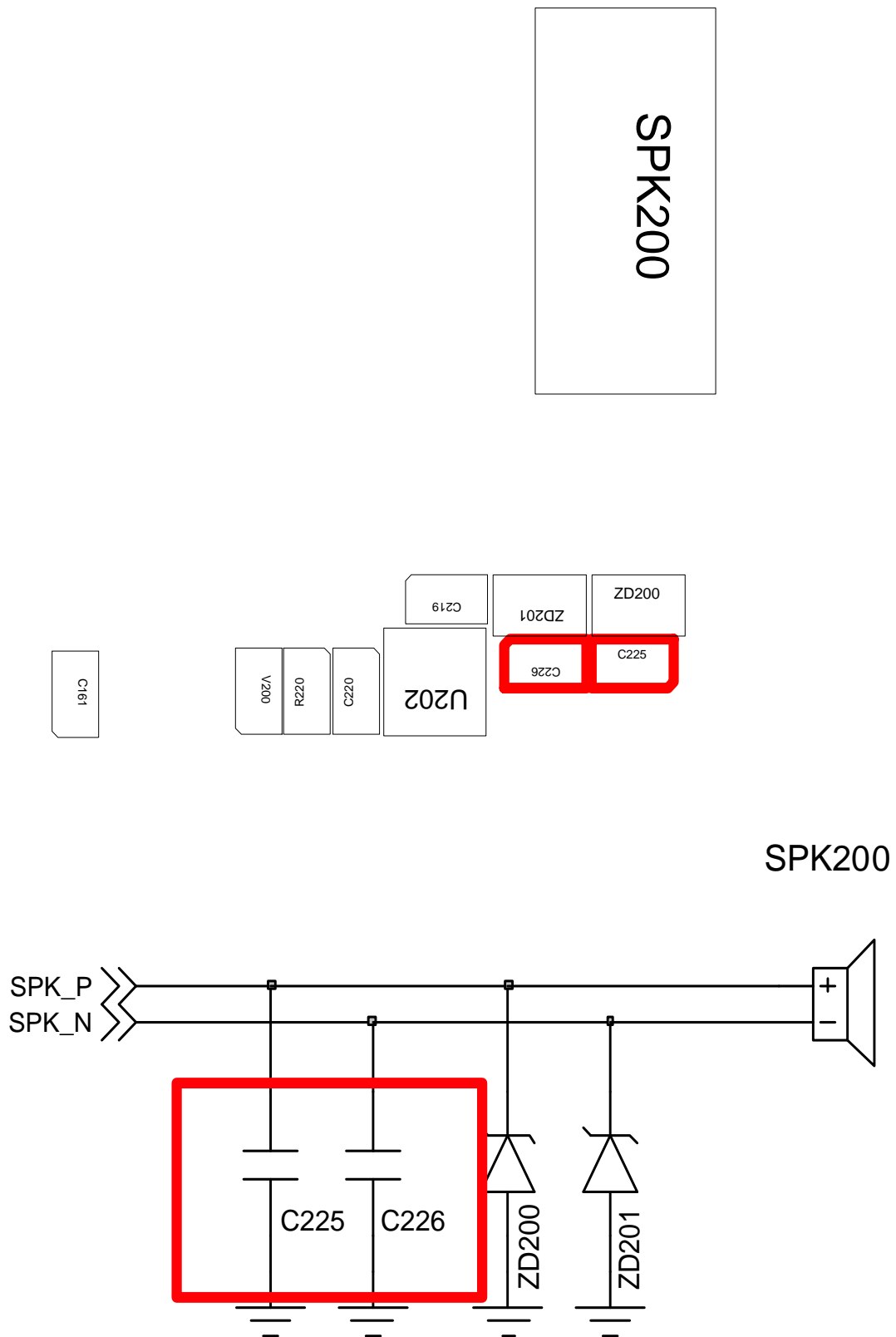

8-3-6. Key Data Input

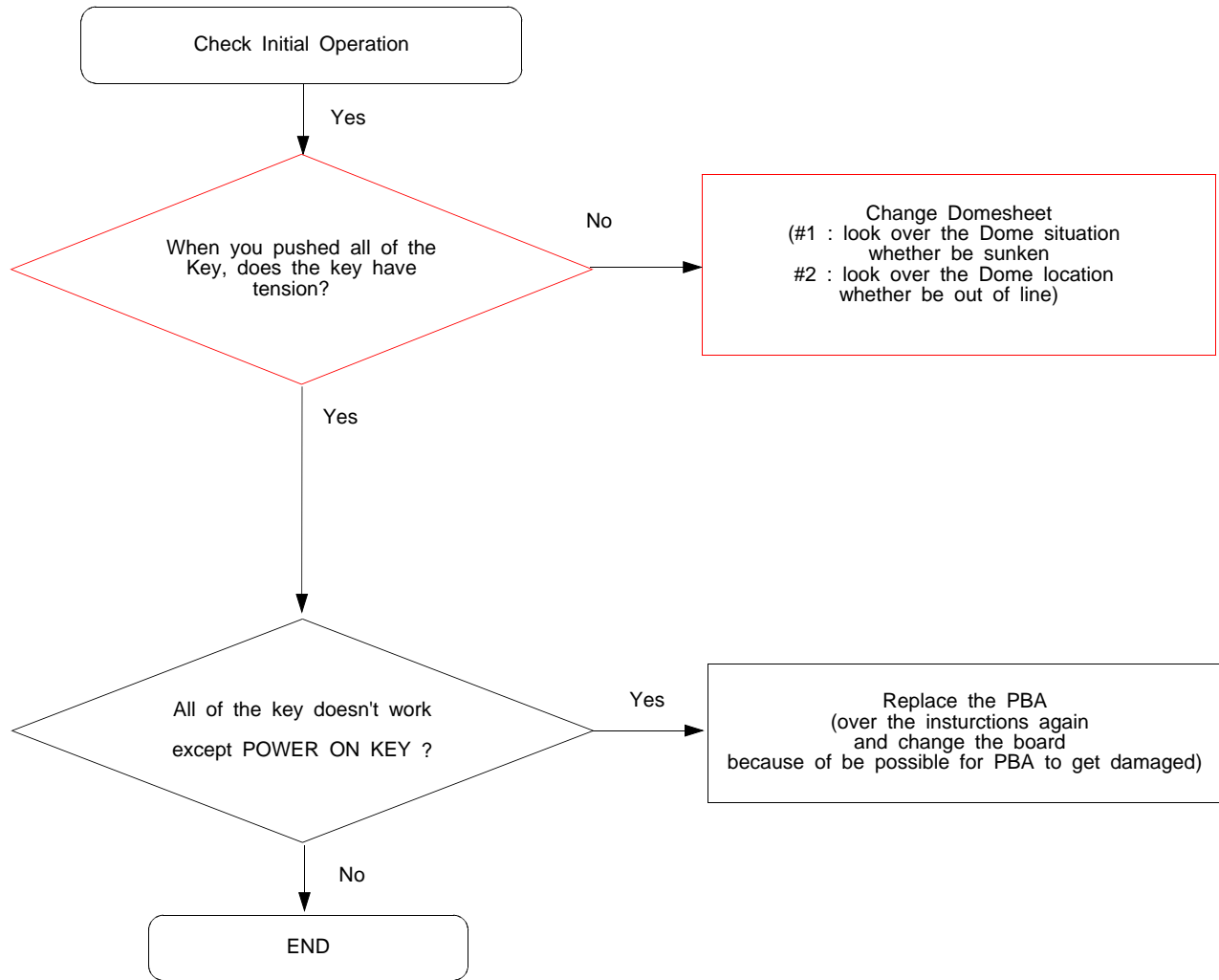

8-3-7. Back Light (for Color Main LCD)

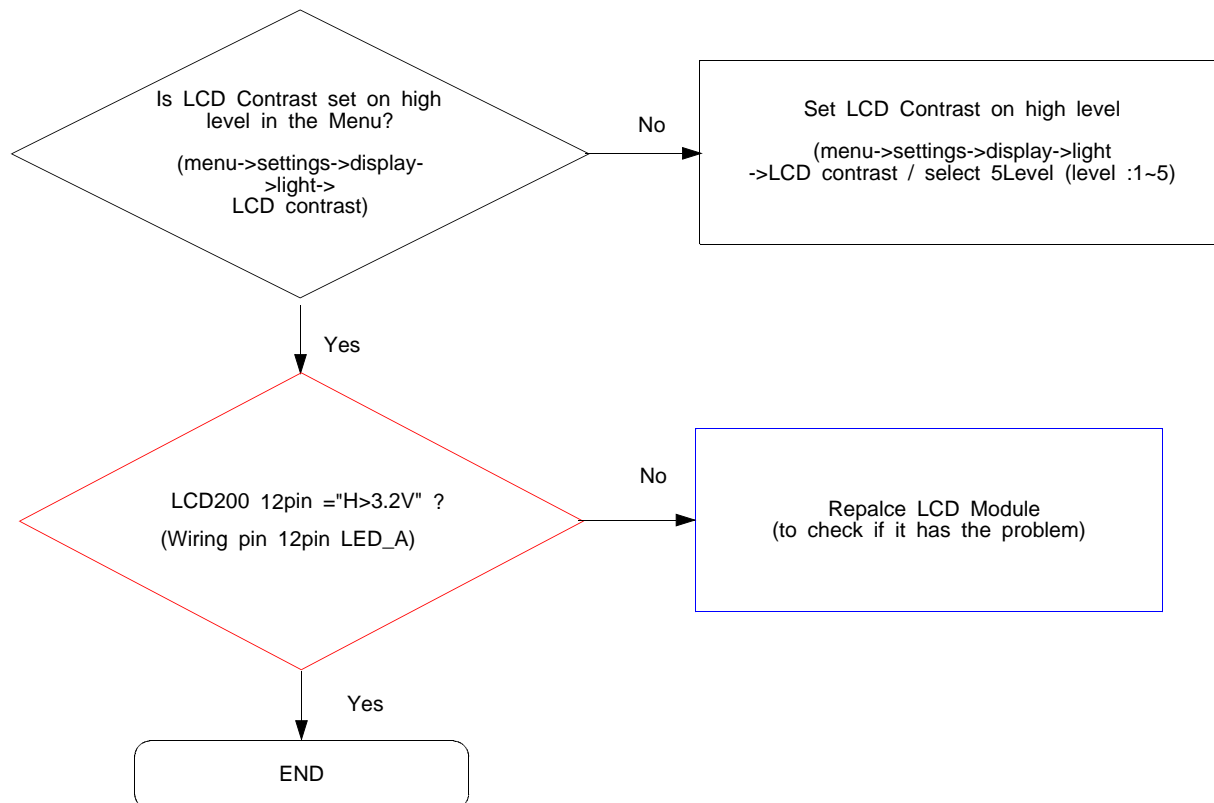

8-3-8. Key Back Light

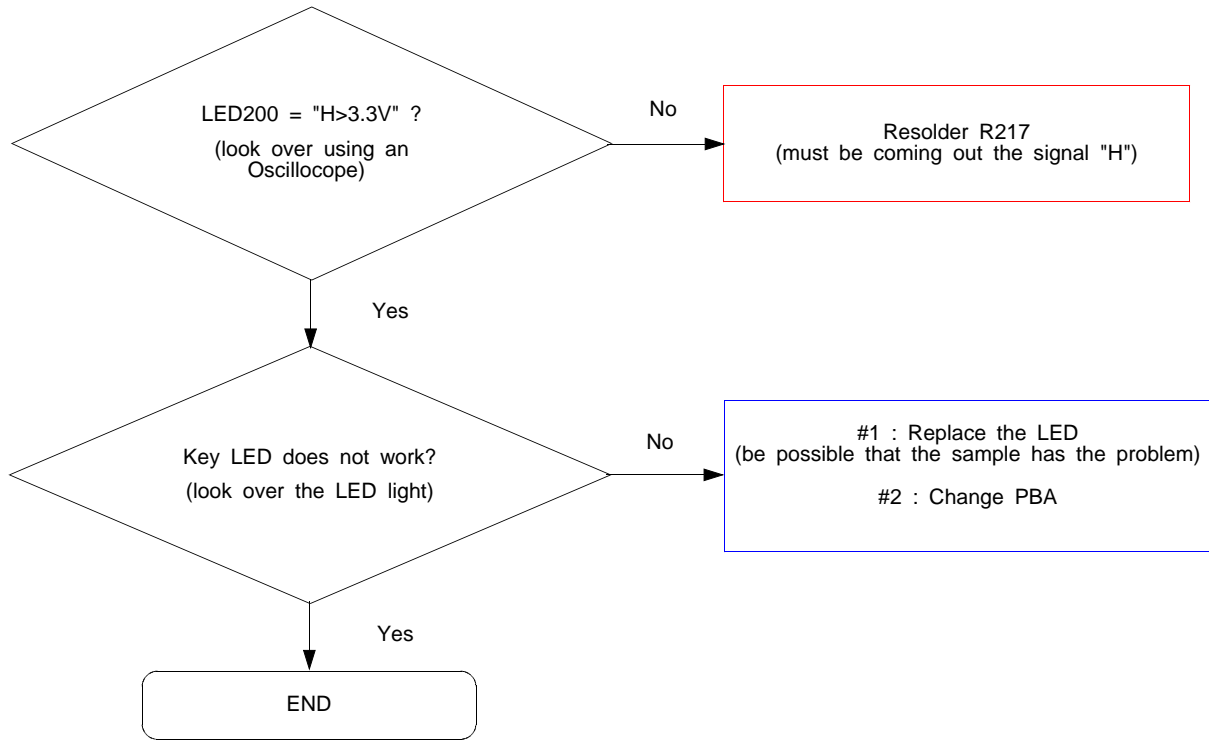

※ presetting 8960

(Rx setting)

Call Setup Screen		
Control	Call Setup	Call Params
Operating Mode	DUT Information	BCH Parameters
Active Cell	IMSI: Called Num:	
Connection Type	Traffic Channel Downlink Power	TCH Parameters
Auto	Burst 1, 2, 3, 4: Unused Bursts:	
Originate Call	Counters	POTCH Parameters
Paging IMSI	Page: RACH: PRACH: Missing Burst: Corrupt Burst: Decode Error:	
Handover Setup	Error Reports	Receiver Control
Cell Info	Burst Timing Error: BLER (Block Error Rate): USF BLER:	
1 of 2	Active Cell Idle Inlier (Offset)	Sys Type: GPRS

< 8960장비 초기화면 >

1. Active Cell
: select GSM or GPRS
2. Connection Type
: select Auto(GSM), BLER(GPRS)
3. BCH Parameter
: select measuring band (DCS or EGSM)
4. Cell power
: -60dBm

(Tx setting)

Call Setup Screen		
Control	Call Setup	Call Params
Operating Mode	DUT Information for IMEI (01040500000064)	BCH Parameters
Active Cell	IMSI: 001010123456789 Called Num: 112	
Connection Type	Traffic Channel Downlink Power	TCH Parameters
Auto	Burst 1, 2, 3, 4: -60.00, Unused Bursts:	
End Call	Counters	POTCH Parameters
Paging IMSI	Page: 2 RACH: 1 PRACH: 0 Missing Burst: 0 Corrupt Burst: 0 Decode Error: 0	
Handover Setup	Error Reports	Receiver Control
Cell Info	Burst Timing Error: 0.50 T BLER (Block Error Rate): USF BLER:	
1 of 2	Active Cell Connected Inlier (Offset)	Sys Type: GSM

< Call이 연결된 화면 >

※ After setting 8960 (EGSM / DCS)

1. After setting, prepare the call setup Display
2. Using an Originate Call, make a call.
3. Confirm the display "connected"
4. start the measuring

8-3-2. GSM900 Receiver

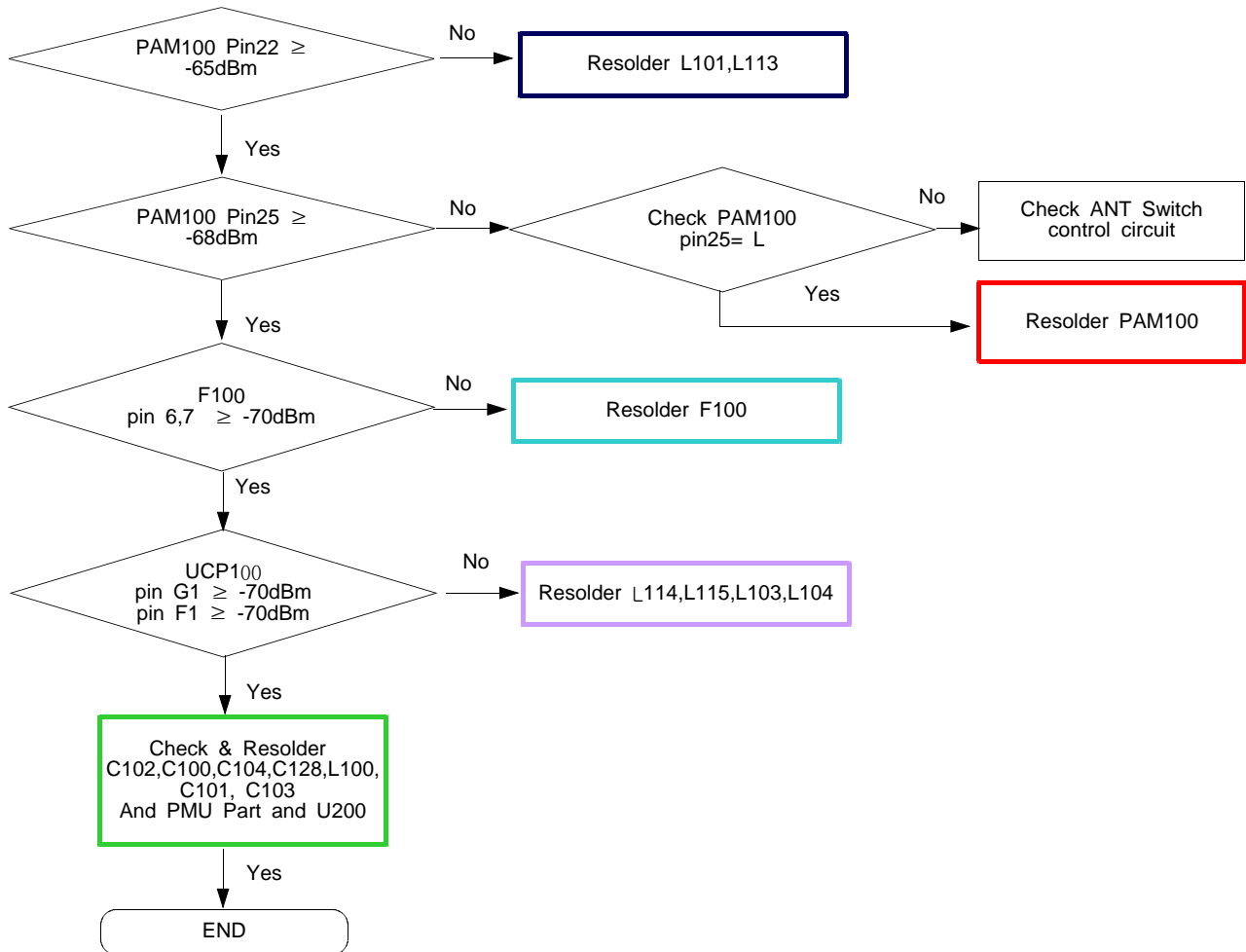

8-3-2. DCS Receiver

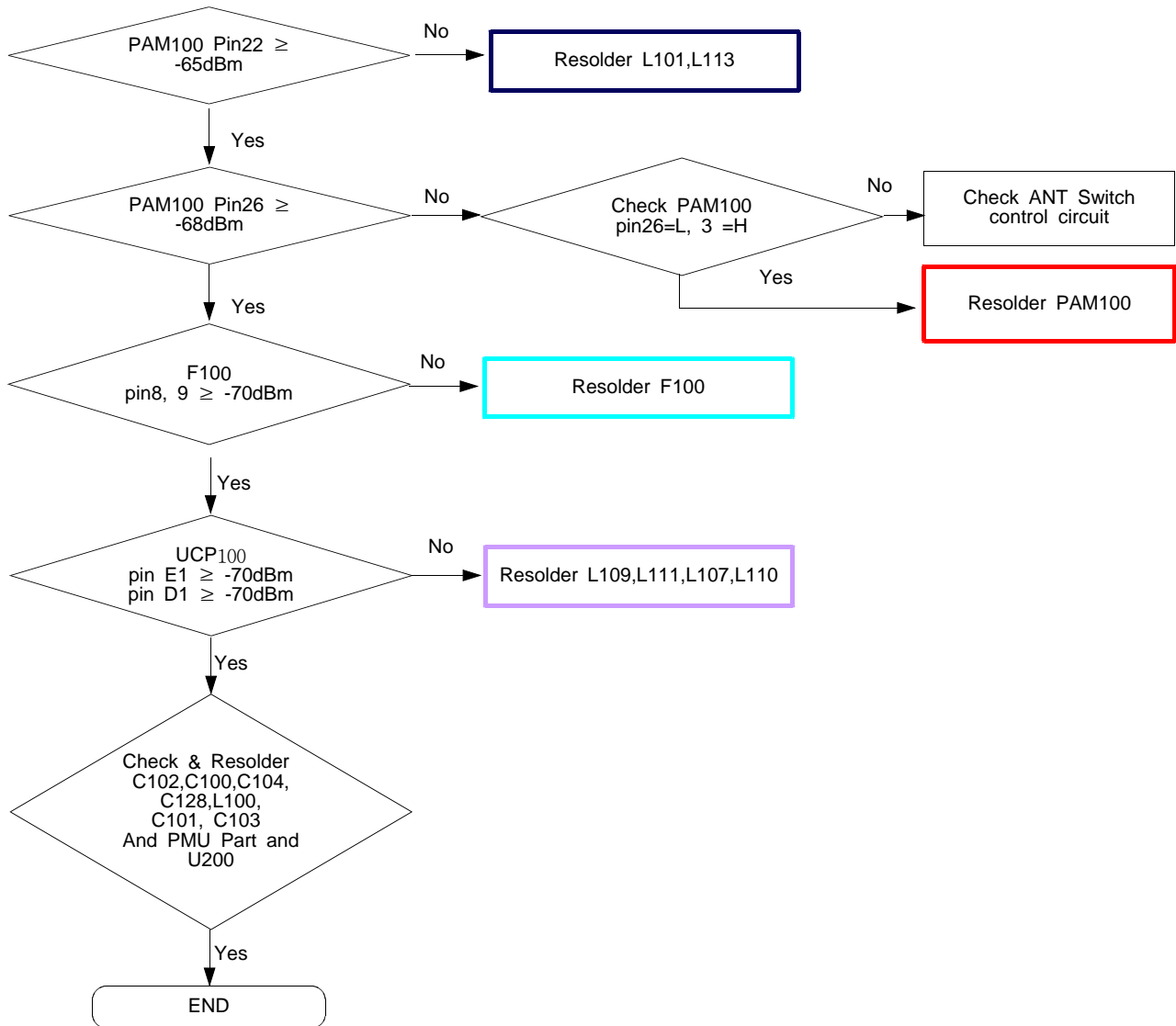

8-3-2. GSM900 Transmitter

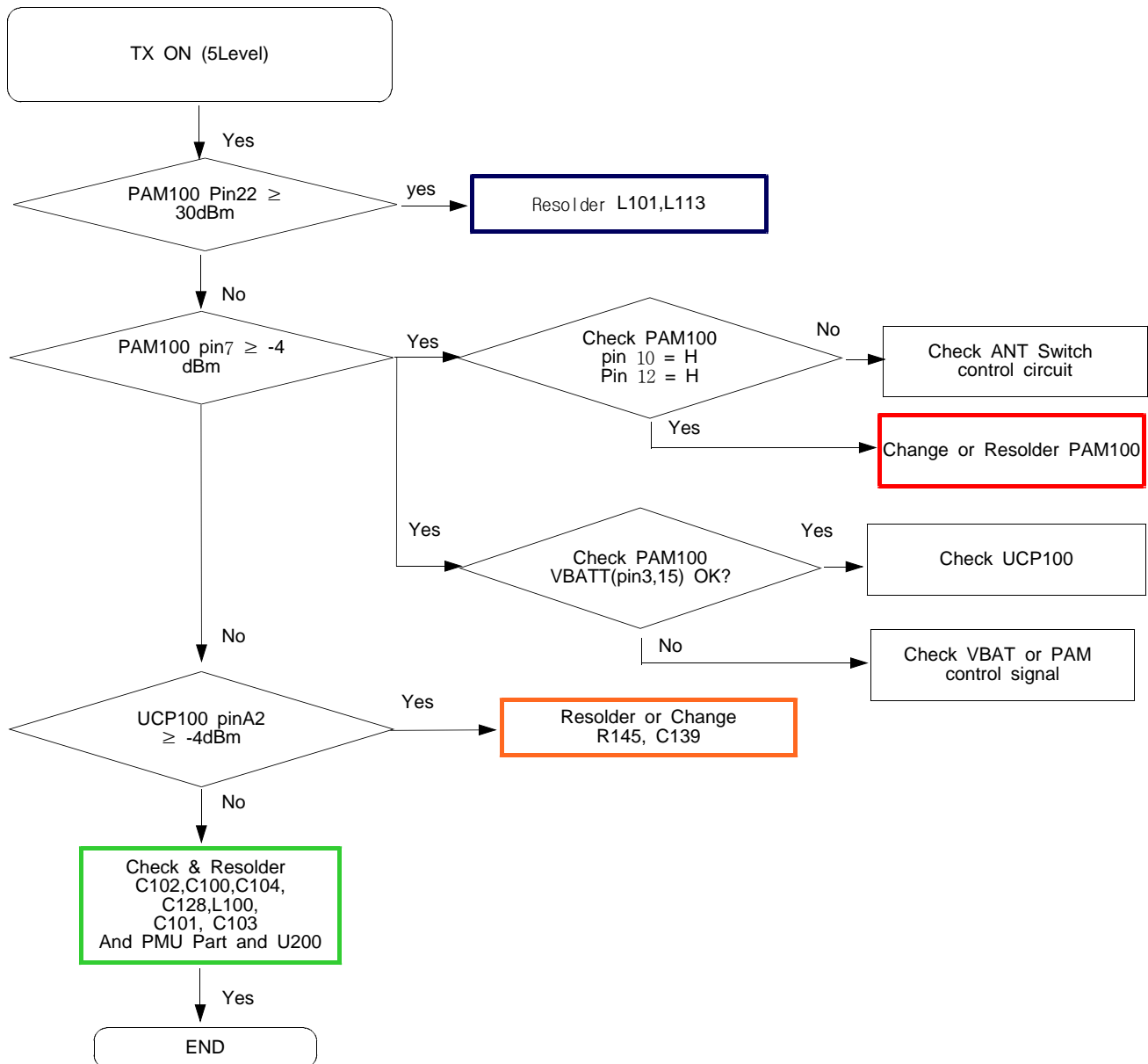

8-3-2. DCS Transmitter

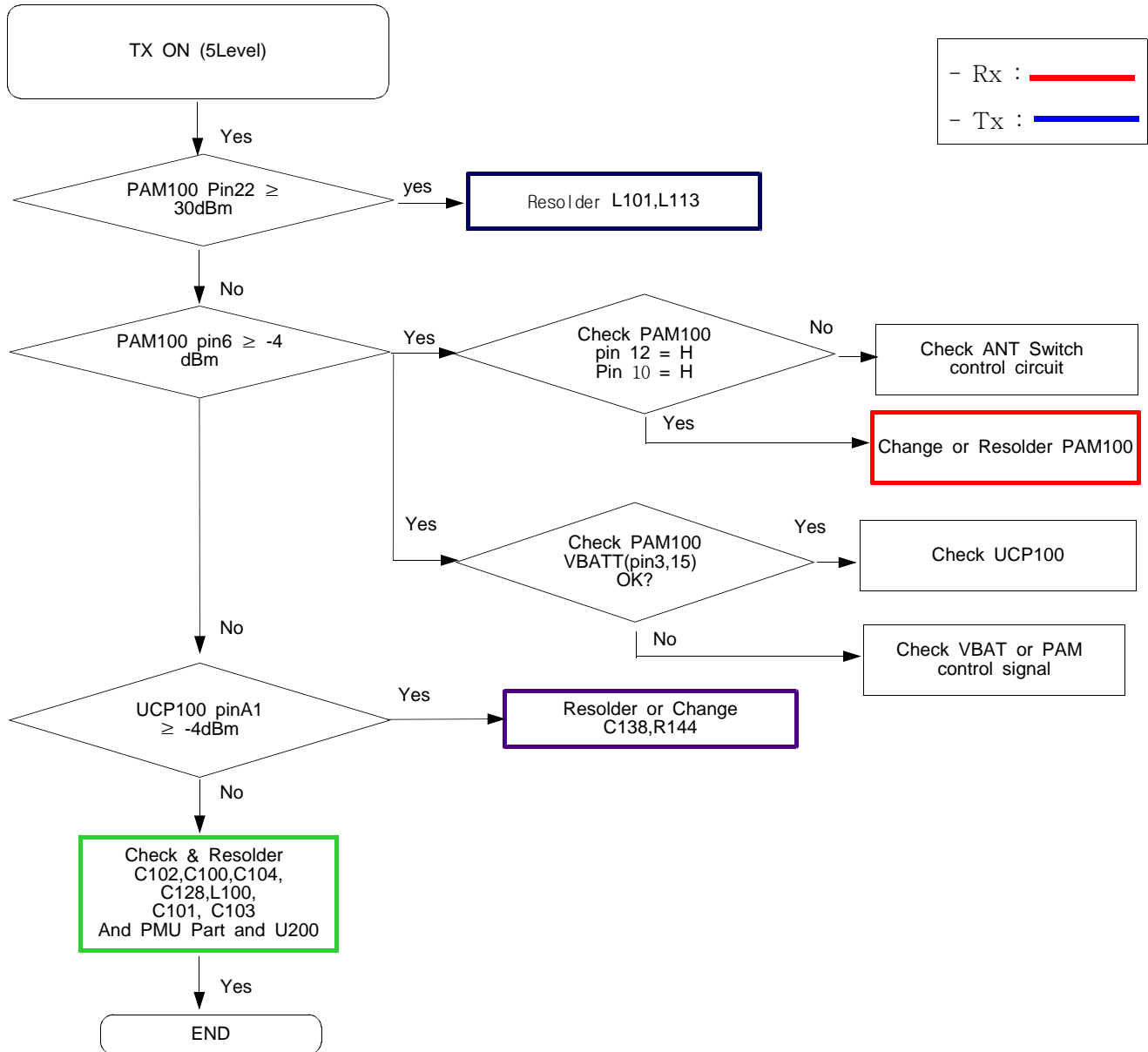

8-4. Service Schematics

- Ball LFBGA Pin out(Top View)

UCP100

	1	2	3	4	5	6	7	8	9	10	11	12	13	14	15	16	17	18	19	
A	VSS RF	VSS RF	VDD 18		VDD SIM0		RF_P AMODE	RF_P ABAND	LCM WR		LCM D[6]		LCM D[1]	SIMR ST1		SIMR ST0	VSS	VSS	A	
B	VSS RF	AVD DBB	VDD 28	VDD SD	VDD SIM1	TEST RST N	TP_Y U	RF_P AEN	LCM CS1	LCM CD	LCM D[8]	LCM D[4]	LCM D[2]	VLC M	LCM D[0]	SIM DA0	GPIO _63	GPIO _0	VSS	B
C		VME MS	RST N		VSS	PAG SM	TP_Y D	PRO DT	RF_V BS3	LCM CS0	LCM D[7]	LCM D[5]	LCM D[3]	IISC LK	SIMC LK1	SIM DA1	SIMC LK0	IISM CK	IISL RCK	C
D		VBA T	VBA T	VSS	ADCI 0		TP_X L	PBIN T	LDO MEM SR	RF_V BS1	LCM RST N	LCM RD		PWM		EXTI NTO	CLK _AUX	IISD O		D
E		VDDR F			ADCI 2	ADCI 3	TP_X R			RF_V BS2			VSS				IISD1	UOC TS	UOR XD	E
F	US/E GSM TX	VSS RF												VSS		SD_C LK1	PAD P_US R	PAD M_US SR	U0T XD	F
G	DCS/ PCS TX	VSS RF			ADCI 1							VDD IO	VDD D			SD_ D3	UOR TS	VDD USB		G
H	US/E GSM RX		VSS RF		VSS				VSS								SD_C LK	SD_ D2	SD_C MD	H
J	US/E GSM RX	VSS RF			VSS		MIC N	MICP	VSS		VSS						SD_ D0	FSM CSN1	SD_ D1	J
K	DCS/ PCS RX P				VSS				VSS		VSS				VDD 18_B VP	KEY1 N[6]				K
L	DCS/ PCS RX	VSS RF	VDD RF_B VP					HEA D_P_ 1						VSS		KEY OUT[4]	KEY1 N[2]	KEY1 N[5]		L
M		VDD COR F		KP_OUT	WHT LED_ IR3			HEA D_P_ R		VSS						KEY1 N[1]	KEY1 N[3]		KEY1 N[0]	M
N	VIBR_OUT T	VSS RF			WHT LED_ IBO				VSS							VSS	KEY OUT[6]	KEY1 N[4]	KEY1 N[7]	N
P		DVDD 18	WHT LED_ IR2	WHT LED_ IR1													KEY OUT[2]		KEY OUT[5]	P
R	WHT LED_ RSET	AVD DBB		VBA T	VBA T			EAR N							VSS		KEY OUT[0]	KEY OUT[3]		R
T	REF_ IN-		VDR V	VSSP A		VSS DCD C		EAR P	RTC3 2KO	MIC BIAS							KEY OUT[1]	ESM D3		T
U	REF_ IN+	REF1_OUT T	VCH G	VSSP A		VSS DCD C		VFB		RTC3 2KI	AIR1	AIL1	HEA DMI CP		MTC K		ESM CLK	ESM D0		U
V	VSS RF	ISEN SE	VBA TSEN	OUT PPA	OUT NPA	VBA TPA	VBA TBU CK	LX	VDD RTC		VBA TBK	HEA DMI C_IN	HEA DMI CN	MTD 1	MTR STN	ESM CSNO	ESM D2	ESM D1	VSS	V
W	VSS RF	VSS RF	VDD PA	OUT PPA	OUT NPA	VBA TPA	VBA TBU CK	LX	VDD AO		VCO M	AVD DVB	VDD 25	MTM S	MTD O			VSS	VSS	W